

Ceramic Disc, RFI and Safety Capacitors

In accordance with IEC recommendations ceramic capacitors are subdivided into two classes:

- CERAMIC CLASS 1 or low-K capacitors are mainly manufactured of titanium dioxide or magnesium silicate
- CERAMIC CLASS 2 or high-K capacitors contain mostly alkaline titanates

MAIN FEATURES		
	CLASS 1	CLASS 2
APPLICATION	For temperature compensation of frequency discriminating circuits and filters, coupling and decoupling in high-frequency circuits where low losses and narrow capacitance tolerances are demanded. As RFI and safety capacitors.	As coupling and decoupling capacitors for such application where higher losses and a reduced capacitance stability are required. As RFI and safety capacitors
PROPERTIES Temperature Dependence Capacitance	High stability of capacitance. Low dissipation factor up to higher frequencies. Defined temperature coefficient of capacitance, positive or negative, linear and reversible. High insulation resistance. No voltage dependence. High long-term stability of electrical values.	High capacitance values with small dimensions. Non-linear dependence of capacitance on temperature.
DC VOLTAGE CAPACITANCE DEPENDENCE	None	Increasing with ϵ
DISSIPATION FACTOR $\tan \delta$	max. $1.5 \cdot 10^{-3}$ (Typical)	max. $35 \cdot 10^{-3}$ (Typical)
INSULATION RESISTANCE	$\geq 10^{10} \Omega$	$\geq 10^9 \Omega$
CAPACITANCE TOLERANCES	< 10 pF: ± 0.25 pF, ± 0.5 pF, ± 1 pF ≥ 10 pF: ± 2 %, ± 5 %, ± 10 %, ± 20 %	± 10 %, ± 20 %, (+ 50 - 20) %, (+ 80 - 20) %
RATED VOLTAGE	Up to 25 kV _{DC}	Up to 15 kV _{DC}

STANDARDS AND SPECIFICATIONS	
GENERAL STANDARDS	
IEC 60062	Marking codes for resistors and capacitors
IEC 60068	Basic environmental testing procedures
Special Standards for Ceramic Capacitors	
EN 130600 and IEC 60384-8	Fixed capacitors of ceramic dielectric, class 1
EN 130700 and IEC 60384-9	Fixed capacitors of ceramic dielectric, class 2
Standards for Special Application Purposes	
CSA C22.2	RFI - and safety capacitors
EN 132400	
IEC 60065	
IEC 60384-14.2	
UL 1414	
VDE 0560, part 2'5.70 and VDE 0860/8.81	



MEASURING AND TESTING CONDITIONS		
	CLASS 1	CLASS 2
CAPACITANCE AND DISSIPATION FACTOR	C ≥ 1000 pF 1 kHz, 1 to 5 V _{RMS} C < 1000 pF 1 MHz, 1 to 5 V _{RMS}	C ≥ 100 pF 1 kHz, 1.0 ± 0.2 V _{RMS} C < 100 pF 1 MHz, 1.0 ± 0.2 V _{RMS}
INSULATION RESISTANCE	Rated voltage < 100 V: ≥ 100 V to < 500 V: ≥ 500 V: Measuring time:	measuring voltage = (10 ± 1) V measuring voltage = (100 ± 15) V measuring voltage = (500 ± 50) V 60 ± 5 s
DIELECTRIC STRENGTH	Rated voltage ≤ 500 V: Test voltage = 2.5 • U _R Testing time: > 500 V: Test voltage = 1.5 • U _R 2 s	

* Climatic test conditions: Temperature 20 °C to 25 °C
Relative humidity 50 % to 70 %

NOMINAL VALUE SERIES ACCORDING TO IEC 60063		
E 6 (± 20 % TOLERANCE)	E 12 (± 10 % TOLERANCE)	E 24 (± 5 % TOLERANCE)
100	100	100
		110
	120	120
		130
150	150	150
		160
	180	180
		200
220	220	220
		240
	270	270
		300
330	330	330
		360
	390	390
		430
470	470	470
		510
	560	560
		620
680	680	680
		750
	820	820
		910

* Intermediate values available on request



CAPACITANCE CODING SYSTEM			
CAPACITANCE VALUE	CODE	CAPACITANCE VALUE	
	p33	0.33 pF	
	3p3	3.3 pF	
	33p	33 pF	
	330p	330 pF	
	n33	330 pF (0.33 nF)	
	3n3	3300 pF (3.3 nF)	
	33n	33000 pF (33 nF)	
	330n	330000 pF (330 nF)	
	μ33	0.33 μF	
	3μ3	3.3 μF	
CAPACITANCE TOLERANCE	CODE LETTER	C - TOLERANCE < 10 pF: IN pF	C- TOLERANCE ≥ 10 pF: IN %
	B	± 0.1	-
	C	± 0.25	-
	D	± 0.5	± 0.5
	F	± 1	± 1
	G	± 2	± 2
	H	-	± 2.5
	J	-	± 5
	K	-	± 10
	L	-	± 15
	M	-	± 20
	R	-	(+ 30 - 20)
	S	-	(+ 50 - 20)
Z	-	(+ 80 - 20)	
RATED VOLTAGE	Clear text		

CERAMIC DIELECTRIC		CERAMIC DIELECTRIC	LETTER CODE	CLASS 1 COLOUR CODE
Class 1 Dielectric		P 100	A	red / violet
		NP 0	C	black
		N 150	P	orange
		N 750	U	violet
		N 1500	V	orange / orange
		N 2200	K	yellow / orange
		N 5600	F	black / orange
Class 2 Dielectric		K 1500	K	
		K 2000	Z	
		K 4000	E	
		K 6000	E	
		K 10000	X	

Note: The actual markings are given in detail on the respective data sheet.



PRODUCTION CODE ACC. TO IEC 60062

- The production code is indicated either with a 2 FIGURE CODE or with a 4 FIGURE CODE:

2 FIGURE CODE (YEAR / MONTH)

- The 1st figure indicates the year and the 2nd figure indicates the month.

YEAR	LETTER CODE
1990	A
1991	B
1992	C
1993	D
1994	E
1995	F
1996	H
1997	J
1998	K
1999	L
2000	M
2001	N
2002	P
2003	R
2004	S
2005	T
2006	U
2007	V
2008	W
2009	X
2010	A
2011	B
2012	C

MONTH	LETTER / NUMBER CODE
JANUARY	1
FEBRUARY	2
MARCH	3
APRIL	4
MAY	5
JUNE	6
JULY	7
AUGUST	8
SEPTEMBER	9
OCTOBER	O
NOVEMBER	N
DECEMBER	D

4 FIGURE CODE (YEAR / WEEK)

- The 1st two figures indicate the year and the second two figures indicate the week.

EXAMPLES:

1998 NOVEMBER = KN
 1999 JULY = L7
 2000 AUGUST = M8
 2001 MAY = N5
 2002 OCTOBER = PO

EXAMPLES:

18th Week 1998 = 9818
 50th Week 1999 = 9950
 32nd Week 2000 = 0032
 41st Week 2001 = 0141
 27th Week 2002 = 0227



MARKING OF THE TEMPERATURE CHARACTERISTIC OF CAPACITANCE FOR CLASS 2 CERAMIC CAPACITORS

ACCORDING TO EN 130700 OR IEC 60384-9

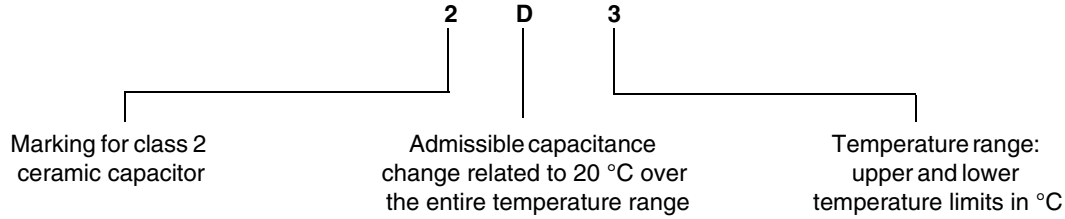

DC VOLTAGE		CODE LETTER
WITHOUT	WITH	
± 10 %	+ 10 %/- 15 %	B
± 20 %	+ 20 %/- 30 %	C
+ 20 %/- 30 %	+ 20 %/- 40 %	D
+ 22 %/- 56 %	+ 22 %/- 70 %	E
+ 30 %/- 80 %	+ 30 %/- 90 %	F
± 15 %	+ 15 %/- 40 %	R
± 15 %	+ 15 %/- 25 %	X

TEMPERATURE RANGE	CODE FIGURE
- 55 to + 125	1
- 55 to + 85	2
- 40 to + 85	3
- 25 to + 85	4
- 10 to + 85	5

ACCORDING TO EIA STANDARD RS 198

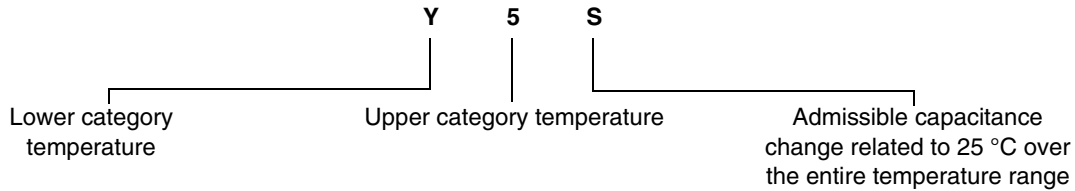

TEMPERATURE	CODE LETTER
- 55 °C	X
- 30 °C	Y
+ 10 °C	Z

TEMPERATURE	CODE FIGURE
+ 45 °C	2
+ 65 °C	4
+ 85 °C	5
+ 105 °C	6
+ 125 °C	7

CHANGE	CODE LETTER
± 1 %	A
± 1.5 %	B
± 2.2 %	C
± 3.3 %	D
± 4.7 %	E
± 7.5 %	F
± 10 %	P
± 15 %	R
± 22 %	S
+ 22 %/- 33 %	T
+ 22 %/- 56 %	U
+ 22 %/- 82 %	V

CLASS 1 CERAMIC TYPE TEMPERATURE COEFFICIENT OF THE CAPACITANCE FOR CLASS 1 CERAMIC CAPACITORS

$$\frac{\Delta C}{C} [\%] = 100 \cdot \alpha \cdot \Delta \vartheta$$

ΔC = Capacitance change
 α = Temperature coefficient in 10 - 6/°C
 $\Delta \vartheta$ = Temperature change in °C

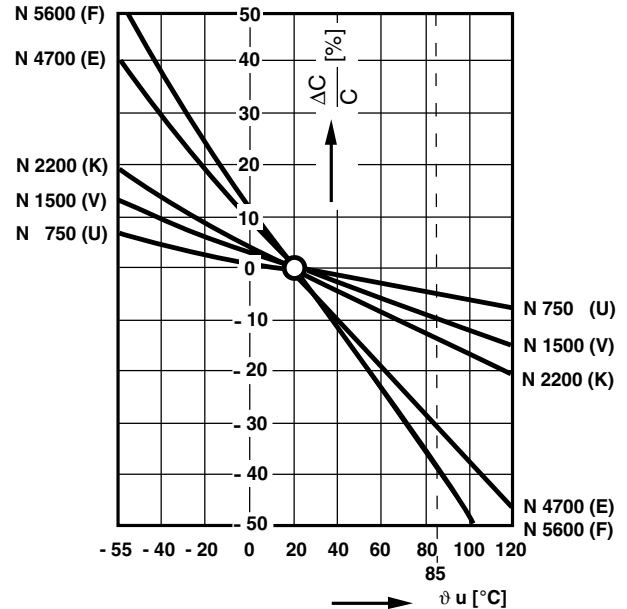
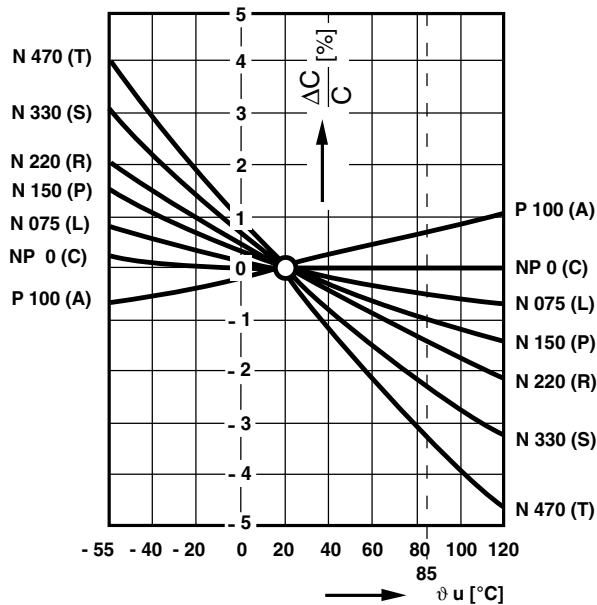

VOLTAGE DEPENDENCE OF CAPACITANCE

None

FREQUENCY DEPENDENCE OF CAPACITANCE

Max. - 2 % at 10 MHz

DISSIPATION FACTOR

- For values greater than 50 pF: see data sheet

- For lower values the dissipation factor is calculated according to the type of ceramic (rated temperature coefficient) under consideration of the capacitance acc. to EN 130600

$$+ 100 \leq \alpha < - 750: \quad 1.5 \cdot \left(\frac{150}{C} + 7 \right) \cdot 10^{-4}$$

$$- 750 \leq \alpha < - 1500: \quad 2 \cdot \left(\frac{150}{C} + 7 \right) \cdot 10^{-4}$$

$$- 1500 \leq \alpha < - 3300: \quad 3 \cdot \left(\frac{150}{C} + 7 \right) \cdot 10^{-4}$$

$$- 3300 \leq \alpha < - 5600: \quad 4 \cdot \left(\frac{150}{C} + 7 \right) \cdot 10^{-4}$$

$$\alpha \geq - 5600: \quad 5 \cdot \left(\frac{150}{C} + 7 \right) \cdot 10^{-4}$$

- The dissipation factor as well as the measuring method to be agreed between manufacturer and user for values lower than 5 pF.



CLASS 2 CERAMIC TYPE

Capacitance Change and Dissipation Factor vs. Temperature

Capacitance Change and Dissipation Factor vs. Frequency

Capacitance Change vs. DC Voltage

CERAMIC DIELECTRIC: 2D3 / K1500/K2000

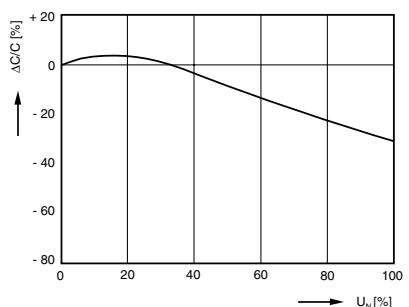
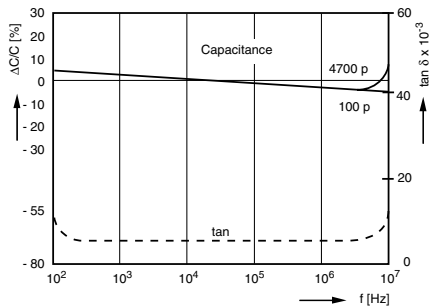
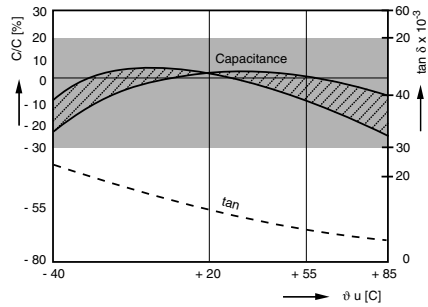

CERAMIC DIELECTRIC: 2E3 / K4000 & K6000

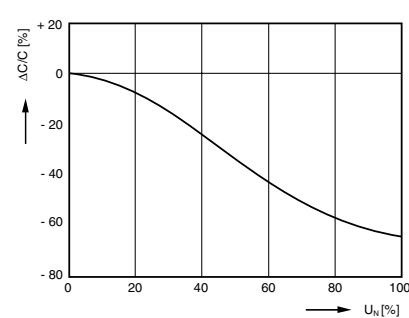
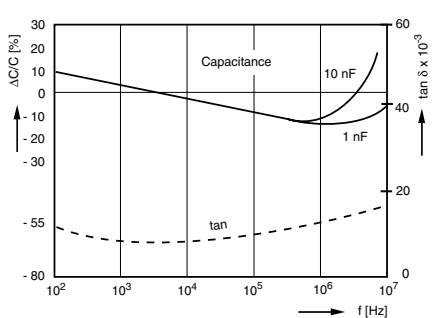
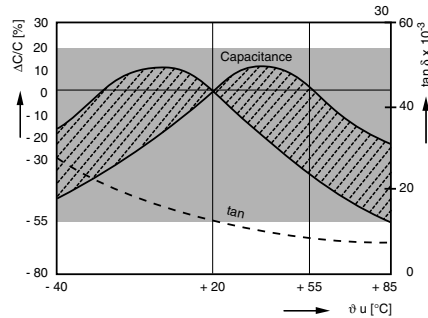

CERAMIC DIELECTRIC: 2F3 / K10000

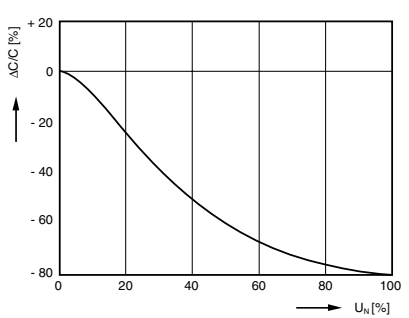
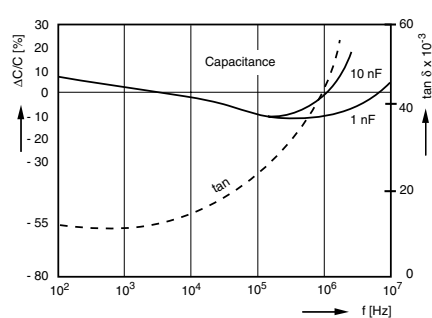
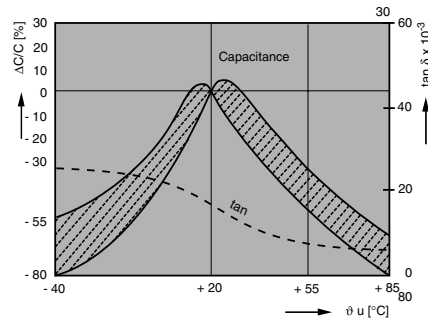



CAPACITANCE “AGEING” OF CERAMIC CAPACITORS

Following the final heat treatment all Class 2 Ceramic Capacitors reduce their capacitance value approximately according to logarithmic law due to their special crystalline construction. This change is called “ageing”. If the capacitors are heat treated, for example when soldering, the capacity increases again to a higher value and the ageing process begins again.

Note:

The level of this de-ageing is dependent on the temperature and the duration of the heat; an almost complete de-ageing is achieved at 150 °C in one hour; these conditions also form the basis for reference measurements when testing. The capacitance change per time decade (ageing constant) differs for the various types of ceramic but typical values can be taken from the table below.

CERAMIC MATERIAL	k 2000	k 4000	k 6000	k 10000
AGEING CONSTANT k	- 4 %	- 3 %	- 4 %	- 5 %

$$k = \frac{100 \cdot (C_{t1} - C_{t2})}{C_{t1} \cdot \log_{10}(t1/t2)}$$

$$C_{t2} = C_{t1} \cdot (1 - k/100 \cdot \log_{10}[t1/t2])$$

t1, t2 = measuring time point (h)
 C_{t1}, C_{t2} = capacitance values for the times t1, t2
 k = ageing constant (%)

REFERENCE MEASUREMENT:

Due to ageing it is necessary to quote an age for reference measurements which can be related to the capacitance with fixed tolerance. According to EN 130700 this time period is 1000 hours.

If the shelf-life of the capacitor is known, the capacitance for t = 1000 h can be calculated with the ageing constant.

In order to avoid the influence of the ageing, it is important to de-age the capacitors before stress-testing. The following procedure is adopted (see also EN 130700) :

- De-ageing at 150 °C, 1 hour
- Storage for 24 hours at normal climate temperature
- Initial measurement
- Stress
- De-ageing at 150 °C, 1 hour
- Storage for 24 hours at normal climate temperature
- Final measurement



COMPONENT CLIMATIC CATEGORY

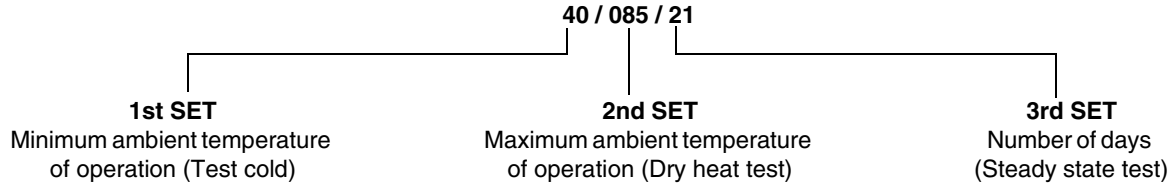

The large number of possible combinations of tests and severities may be reduced by the selection of a few standard groupings according to IEC 60068-1

CATEGORY EXAMPLES ACC. TO IEC 60068-1
25 / 085 / 04
25 / 085 / 21
40 / 085 / 21
55 / 125 / 21
55 / 125 / 56

First set: Two digits denoting the minimum ambient temperature of operation (Cold test)

65	- 65 °C
55	- 55 °C
40	- 40 °C
25	- 25 °C
10	- 10 °C
00	0 °C
05	+ 5 °C

Second set: Three digits denoting the maximum ambient temperature (Dry heat test)

155	+ 155 °C
125	+ 125 °C
110	+ 110 °C
090	+ 90 °C
085	+ 85 °C
080	+ 80 °C
075	+ 75 °C
070	+ 70 °C
065	+ 65 °C
060	+ 60 °C
055	+ 55 °C

Third set: Two digits denoting the number of days of the damp heat steady state test (Ca)

56	56 days
21	21 days
10	10 days
04	04 days
00	The component is not required to be exposed to damp heat



STORAGE

The capacitors must not be stored in a corrosive atmosphere, where sulphide or chloride gas, acid, alkali or salt are present. Exposure of the components to moisture, should be avoided. The solderability of the leads is not affected by storage of up to 24 months (temperature + 10 °C to + 35 °C, relative humidity up to 60 %RH). Class 2 Ceramic Dielectric Capacitors are also subject to ageing see previous page.

SOLDERING

SOLDERING SPECIFICATIONS		
Soldering test for capacitors with wire leads: (according to IEC 60068-2-20, solder bath method)		
	SOLDERABILITY	RESISTANCE TO SOLDERING HEAT
Soldering Temperature	(235 ± 5) °C	(260 ± 5) °C
Soldering Duration	(2 ± 0.5) sec	(10 ± 1) sec
Distance from Component Body	≥ 2 mm	≥ 5 mm

SOLDERING RECOMMENDATIONS

Soldering of the component should be achieved using a SN60/40 type or a silver-bearing SN62/36/2AG type solder. Ceramic capacitors are very sensitive to rapid changes in temperature (Thermal shock) therefore the solder heat resistance specification (see above table) should not be exceeded. Subjecting the capacitor to excessive heating may result in thermal shocks that can crack the ceramic body. Similarly, excessive heating can cause the internal solder junction to melt.

CLEANING

The components should be cleaned immediately following the soldering operation with vapor degreasers.

SOLVENT RESISTANCE

The coating and marking of the capacitors are resistant to the following test method: IEC 60068-2-45 (Method XA)

MOUNTING

We do not recommend modifying the lead terminals, e.g. bending or cropping. This action could break the coating or crack the ceramic insert. If however, the lead must be modified in any way, we recommend support of the lead with a clamping fixture next to the coating.



AQL / FIT VALUES / SUPPLIED QUALITY

AQL 0.1 FOR THE SUM OF THE ELECTRIC MAIN FAULTS

- C - Tolerance > 1.5 x Tolerance Limit
- DF > 1.5 x Catalog Value
- R_{IS} < Catalog Value
- Inadequate Dielectric Breakdown
- Interruption

AQL 0.25 FOR THE SUM OF THE MECHANICAL MAIN FAULTS

- Marking wrong or missing
- Dimensions out of Tolerance
- Coating Failure
- Lead Space out of Tolerance
- Poor Solderability of Leads
- Wrong Lead Length

AQL 0.65 FOR SECONDARY FAULTS

- Coating Extension out of Tolerance
- Marking Incomplete
- Tape Dimensions out of Tolerance

Testing in accordance to IEC60410

NOTE:

The following agreements are possible on request:

- Lower AQL values
- Confirmed Initial random sampling test with appropriate report
- Report on production test findings
- Agreement on ppm concept

RELIABILITY

By careful control of the manufacturing process stages, the quality of the product is maintained at the highest possible level. To obtain data on the reliability of our ceramic capacitors, many long-term tests under increased temperature and voltage conditions have been carried out in our laboratories.

Based on the results of these tests, the following can be stated:

Reference Conditions:	Ambient Temperature:	$(40 \pm 2) ^\circ\text{C}$
	Relative Humidity:	$(60 \pm 2) \%$
	Electrical Stress:	50 % Rated Voltage (U_R)
Failure Criteria:	Short Circuit ($R \leq 10^{-5} \Omega$) or open circuit	
Failure Tests:	Class 1 Capacitors:	$\lambda = 2 \times 10^{-9} \text{ h}^{-1}$
	Class 2 Capacitors:	$\lambda = 5 \times 10^{-9} \text{ h}^{-1}$

By derating the voltage load, greatly increased reliability can be predicted.

Temperature, up to the maximum category temperature, is not believed to significantly affect the reliability.



PRODUCTION FLOWCHART

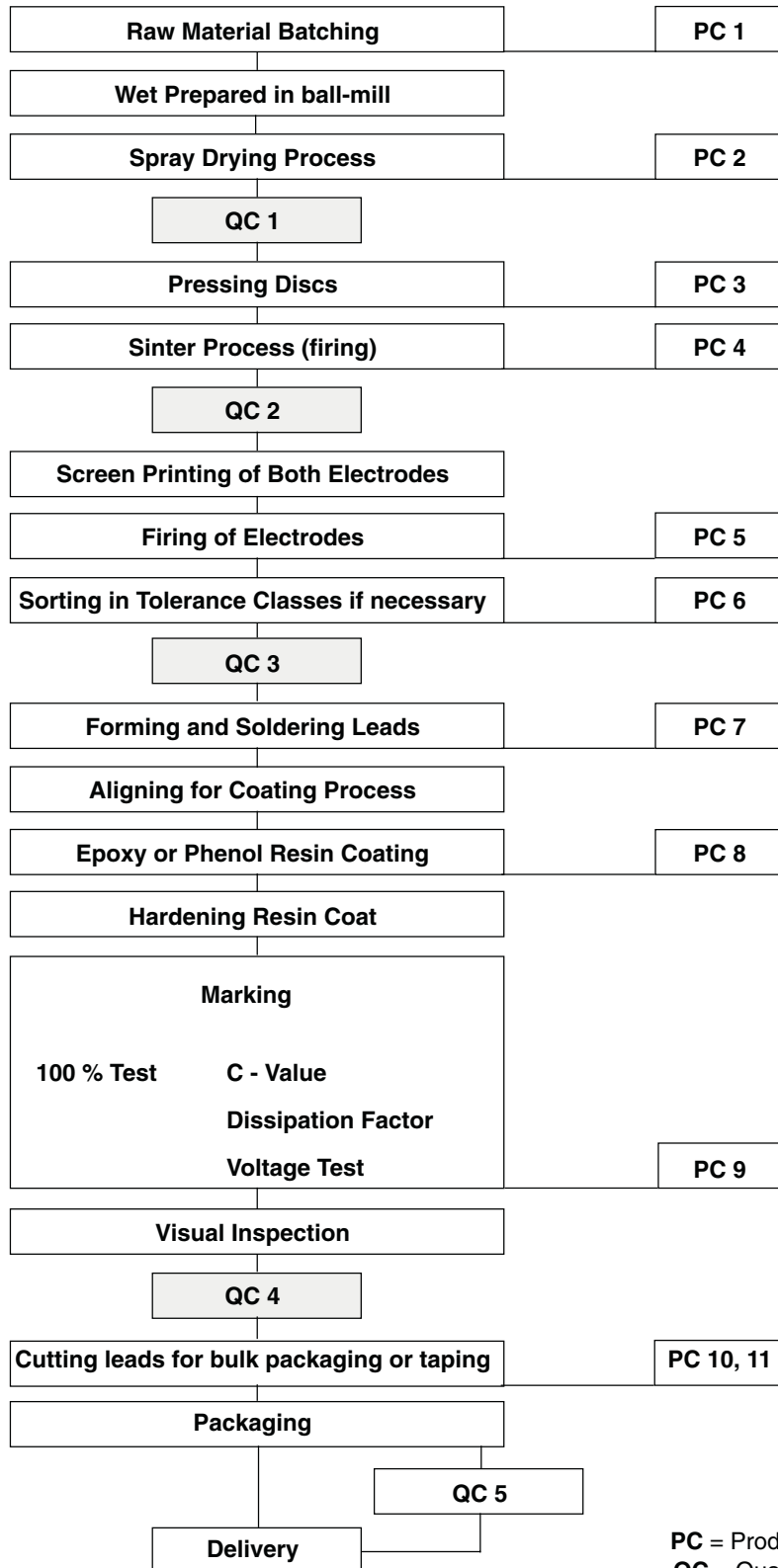

PC = Production Control
QC = Quality Control



AVAILABLE STANDARD LEAD CONFIGURATIONS

FORM 1 STRAIGHT LEAD

e	3.0 MAX.
L	30 - 3 or 10 ± 1

d	0.6 or 0.8
F	5.0*) / 7.5 / 10 / 12.5

*) only when d = 0.6

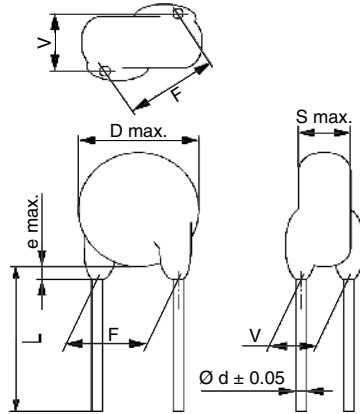

FORM 4 7.5 to 5.0 CRIMP

d	0.6
L	3.0 MIN.

D	B
≤ 9	6.8 ± 0.7
> 9	7.5 ± 0.7

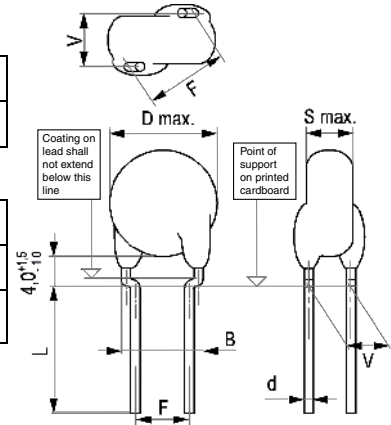

FORM 2 INSIDE CRIMP

d	0.6 or 0.8
L	3.0 MIN., 1.0 absolute

F	A
5.0*)	4.0 - 1 + 0.5
7.5	4.0 ± 1.5
10	5.0 ± 1.5
12.5	6.0 ± 1.5

*) only when d = 0.6
WYO series: Kink = 1.4 + 0.5 - 0.2

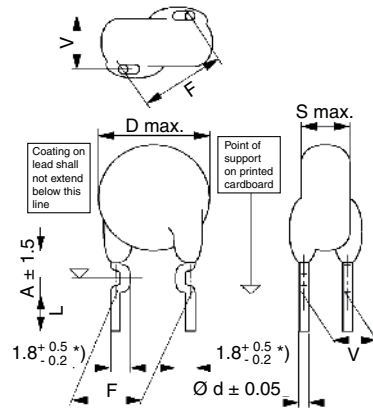

FORM 5 SNAP-IN

d	0.6	0.8
F	5.0* / 7.5 / 10 / 12.5	
L	2.8 MIN.	3.5 MIN.
H	2.6	3.3
P1	1.25	1.65
P2	1.65	1.95

*) only when d = 0.6

D	B
≤ 8	6.0 ± 1.5
> 8	7.0 ± 1.5

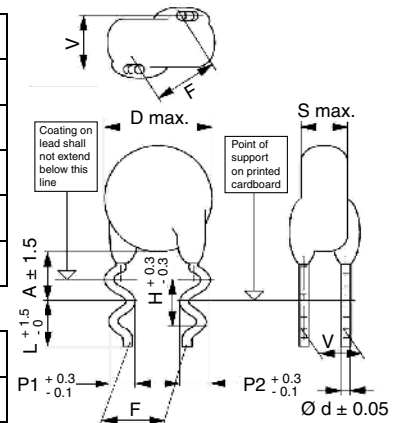

FORM 3 OUTSIDE CRIMP

F	d	A
5.0*)	0.6	5.0
7.5	0.6	5.0
7.5	0.6	6.0
10	0.6	6.0
10	0.6	6.0
12.5	0.6	6.0
12.5	0.6	6.0

*) only when d = 0.6

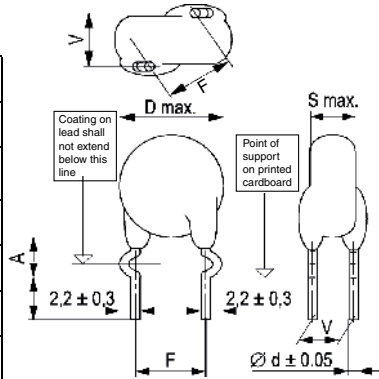

FORM 6 INLINE WIRE

F	d	A
7.5	0.6	4.5 MAX.
10	0.8	6.0 MAX.
12.5	0.8	6.0 MAX.

F	L
7.5	2.8 MIN. 1.5 absolute
10	3.0 MIN. 2.0 absolute
12.5	3.0 MIN. 2.0 absolute

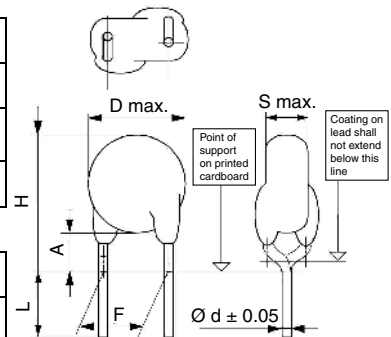



RADIAL TAPING OF CERAMIC DISC CAPACITORS					
DESIGNATION	SYMBOL	TAPING P	TAPING T	TAPING U	TAPING F
Pitch of Component	P		12.7 ± 1		25.4 ± 1
Pitch of sprocket hole	P ₀		12.7 ± 0.3		12.7 ± 0.3
Distance, hole to lead	P ₁		3.85 ± 0.7		(0.5F) ± 0.7
Distance, hole to center of component	P ₂		6.35 ± 1.3		12.7 ± 1.3
Lead spacing	F		5.0 / 7.5 + 0.8 - 0.2		5/7.5/10/12.5 ± 0.8
Average deviation across tape	Δh		± 2.0 max.		± 3.0 max.
Average deviation in direction of reeling	ΔP		± 1.3 max.		± 1.3 max.
Carrier tape width	W		18.0 + 1 - 0.5		18.0 + 1 - 0.5
Hold-down tape width	W ₀		6.0		6.0
Position of sprocket hole	W ₁		9.0 + 0.75 - 0.5		9.0 + 0.75 - 0.5
Distance of hold-down tape	W ₂		3.0 max.		3.0 max.
Distance between the abscissa and the bottom plane of the component body	H	16.5 ± 0.5	18.0 + 2 - 0	20 ± 1	16.5 ± 0.5 18.0 + 2 - 0 20.0 ± 1
Distance between the abscissa and the reference plane of the component with crimped leads.	H ₀		16.0 ± 0.5		16.0 ± 0.5
Length of cut leads	L		11.0 max.		11.0 max.
Diameter of sprocket hole	D ₀		4.0 ± 0.2		4.0 ± 0.2
Total tape thickness	t		0.9 max.		0.9 max.

PACKAGING VERSIONS

Reel Packaging

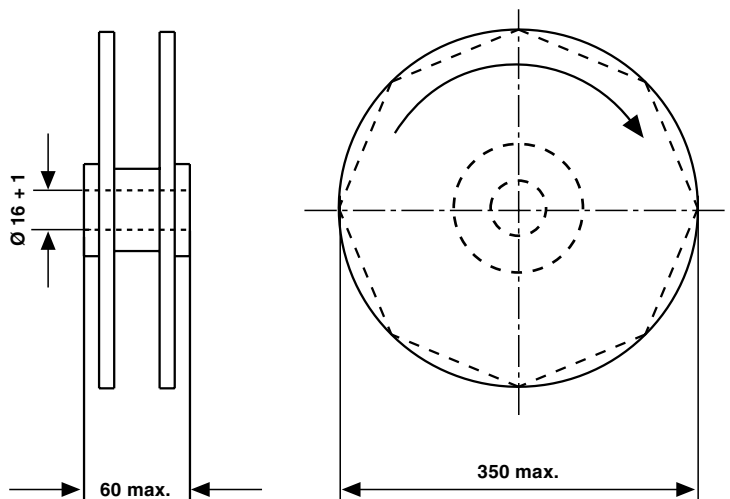

Ammo Packaging

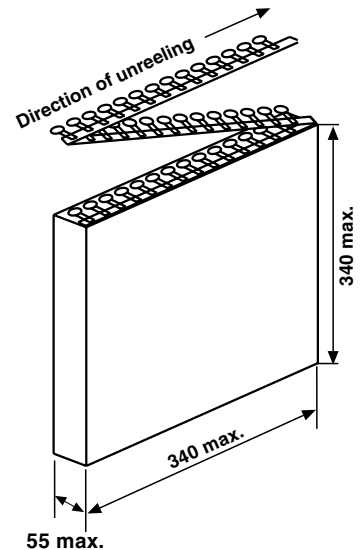

General Information

Vishay Draloric

Ceramic Disc, RFI and Safety Capacitors



TAPING P / T / U
COMPONENT PITCH 0.5 INCH
LEAD SPACING 5.0 MM

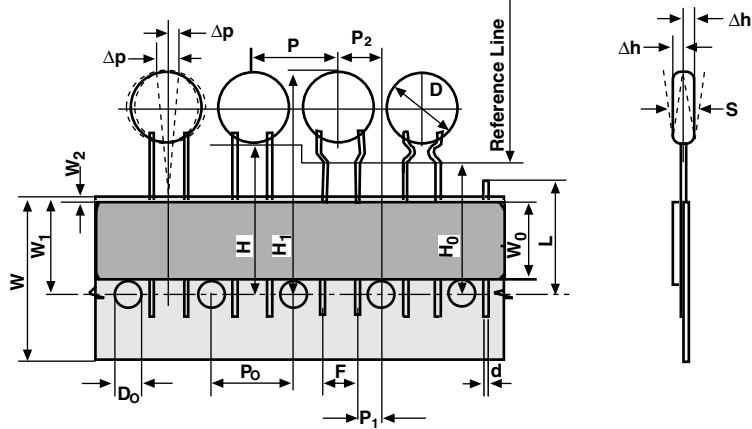

TAPING P / T / U
COMPONENT PITCH 0.5 INCH
LEAD SPACING 7.5 MM

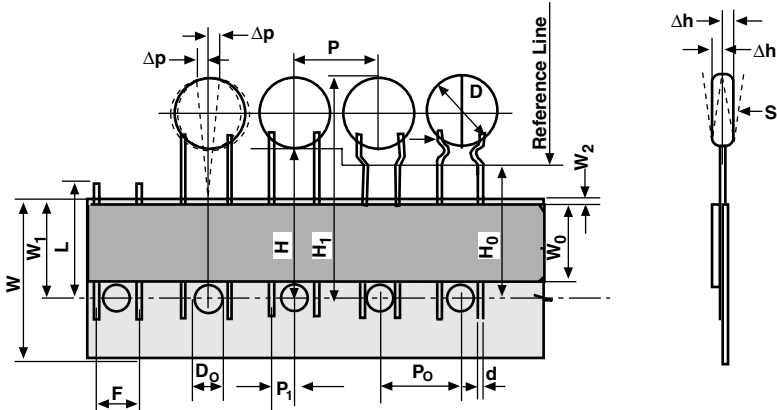

TAPING F
COMPONENT PITCH 1.0 INCH
LEAD SPACING 5.0 / 7.5 / 10 / 12.5 MM

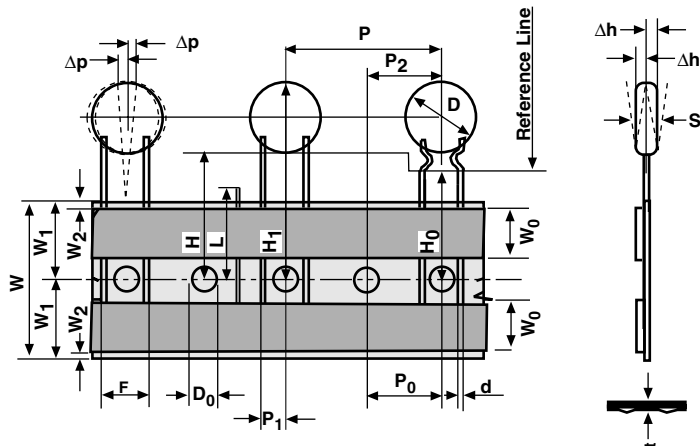

- Pulling force from the tape ≥ 5 N
- Tensile strength of tape ≥ 15 N
- Unreeling force of tape from reel ≥ 2.5 N

Maximum 0.5 % of all components on reel may be missing. A maximum of 3 consecutive components may be missing provided this gap is followed by 6 consecutive components. The splices shall have the same minimum strength as the tape. The splices must be not thicker than 1.5 mm, the sprocket holes may not be effected.



The ordering code is made up of a 14-digit or 15-digit code.

ORDERING INFORMATION						
EXAMPLE H... / I... / V... / W... Series (14-digit code)						
WYO	472	M	CM	CF0	K	R
1 2 3	4 5 6	7	8 9	10 11 12	13	14
CAPACITOR SERIES	CAPACITANCE VALUE IN pF	TOLERANCE	RATED VOLTAGE	LEAD CONFIGURATION	INTERNAL CODE	RoHS
To be taken from the respective individual data sheet	1st Two Digits represent significant figures 3rd Digit is the multiplier (x10) e.g. 1.6 pF = 916 10 pF = 100 120 pF = 121 4700 pF = 472 22 nF = 223	C = ± 0.25 pF D = ± 0.5 pF J = ± 5 % K = ± 10 % M = ± 20 % S = + 50 - 20 % Z = + 80 - 20 %	AQ = 500 V- BA = 1 kV- BB = 2 kV- BC = 3 kV- BD = 4 kV- BE = 5 kV- BF = 6 kV- BP = 8 kV- BH = 10 kV- BJ = 15 kV- BQ = 25 kV- <u>W1X Series:</u> CV = 275 V _{AC} <u>WYO Series:</u> CM = 250 / 250 / 440 V _{AC} <u>VKO Series:</u> CQ = 250 / 300 / 440 V _{AC} <u>WKO Series:</u> CP = 250 / 300 / 440 V _{AC} <u>VKP Series:</u> CQ = 250 / 500 / 760 V _{AC} <u>WKP Series:</u> CP = 250 / 500 / 760 V _{AC}	STRAIGHT LEADS OR INSIDE CRIMP. <u>10th Digit</u> LEAD SPACING B = 5.0 mm C = 7.5 mm D = 10 mm E = 12.5 mm <u>11th Digit*</u> LEAD LENGTH / DIA B = 6 + 0 - 1 / 0.6 D = 10 ± 1 / 0.6 H = 10 ± 1 / 0.8 Y = ≥ 20 / 0.6 F = 30 - 3 / 0.6 J = 30 - 3 / 0.8 S = ≥ 30 / 0.6 P = 45 ± 2 / 0.6 R = Taped & Reeled L = Taped & Ammo <u>12th Digit *</u> 0 = bulk Other = special type OTHER LEAD CONFIGURATION: <u>10th Digit</u> Q = Snap-In T = Outside crimp U = 7.5 to 5 mm Y = Inline Wire SPECIALITY <u>10th Digit</u> R or S	Internal code	 RoHS COMPLIANT RoHS compliant indicator

* The schematic of the 11th and 12th digit is only applicable if the 10th digit is B, C, D or E

EXAMPLE RL. Series (15-digit code)						
RLA	922	D	AQ	BY0	S1	R
1 2 3	4 5 6	7	8 9	10 11 12	13 14	15
CAPACITOR SERIES	CAPACITANCE VALUE IN pF	TOLERANCE	RATED VOLTAGE	LEAD CONFIGURATION	INTERNAL CODE	RoHS



ORDER CODE, 10, 11 AND 12 DIGIT

BULK PACKAGING						
	LEAD LENGTH L	LEAD DIA d	LEAD SPACING F			
			5 mm	7.5 mm	10 mm	12.5 mm
STRAIGHT LEADS	30 - 3 mm	0.6 mm	BF0	CF0	DF0	EF0
		0.8 mm	-	CJ0	DJ0	EJ0
	25 + 5 mm	0.6 mm	BY0	CY0	-	-
		10 ± 1 mm	0.6 mm	BD0	CD0	DD0
PREFORMED LEADS INSIDE CRIMP	30 - 3 mm	0.6 mm	BFG	CFG	DFG	EFG
		0.8 mm	-	CJG	DJG	EJG
PREFORMED LEADS OUTSIDE CRIMP	5.0 ± 1 mm	0.6 mm	TA0	TC0	TE0	TG0
		0.8 mm	-	TD0	TF0	TH0
PREFORMED LEADS SNAP-IN	min. 2.8 mm	0.6 mm	QA0	QC0	QE0	QG0
	min. 3.5 mm	0.8 mm	-	QD0	QF0	QH0
INLINE WIRE	min. 2.8 mm	0.6 mm	-	YC0	YE0	YG0
	min. 3.0 mm	0.8 mm	-	-	YF0	YH0

REEL PACKAGING COMPONENT PITCH 12.7 mm						
	TAPING P		TAPING T		TAPING U	
	H = 16.5		H = 18.0 mm straight leads only H ₀ = 16.0 mm preformed leads only		H = 20.0 mm	
LEAD DIAMETER 0.6 mm						
LEAD SPACING F	5 mm	7.5 mm	5 mm	7.5 mm	5 mm	7.5 mm
BODY DIAMETER D	valid for ≤ 12 mm STANDARD (> 12 mm to ≤ 13 mm on request)					
STRAIGHT LEADS	BRE	CRE	BRA	CRA	BRC	CRC
PREFORMED LEADS INSIDE CRIMP	-	-	BRB	CRB	-	-
PREFORMED LEADS OUTSIDE	-	-	TAR	TCR	-	-
PREFORMED LEADS 7.5 mm to 5 mm	-	-	UAR	-	-	-
PERFORMED LEADS SNAP-IN	-	-	QAR	QCR	-	-
INLINE WIRE	-	-	YAR	YCR	-	-

REEL PACKAGING COMPONENT PITCH 25.4 mm								
	TAPING F							
	5 mm		7.5 mm		10 mm		12.5 mm	
BODY DIAMETER D			> 12 mm		ALL DIAMETERS			
STRAIGHT LEADS	H = 16.5 mm		BRT	CRT	DRT	ERT		
	H = 18.0 mm		BRU	CRU	DRU	ERU		
	H = 20.0 mm		BRY	CRY	DRY	ERY		
PREFORMED LEADS INSIDE CRIMP	H ₀ = 16.0 mm		BRZ	CRZ	DRZ	ERZ		
INLINE WIRE	H ₀ = 16.0 mm		YRB	YRC	YRD	YRE		

* The lead diameter of the taped components is depending on the capacitance value and corresponds with the data given in the individual data sheets.

AMMO PACKAGING COMPONENT PITCH 12.7 mm						
	TAPING P		TAPING T		TAPING U	
	H = 16.5		H = 18.0 mm straight leads only H ₀ = 16.0 mm preformed leads only		H = 20.0 mm	
LEAD DIAMETER 0.6 mm						
LEAD SPACING F	5 mm	7.5 mm	5 mm	7.5 mm	5 mm	7.5 mm
DISC DIAMETER D	Valid for ≤ 12 mm STANDARD (> 12 mm to ≤ 13 mm on request)					
STRAIGHT LEADS	BLE	-	BLA	CLA	BLC	-
PREFORMED LEADS INSIDE CRIMP	-	-	BLB	-	-	-
PREFORMED LEADS 7.5 mm to 5 mm	-	-	UAL	-	-	-
INLINE WIRE	-	-	YAL	-	-	-